

# HARVARD<sup>TM</sup>

## EMERGENCY 2-WAY RADIO

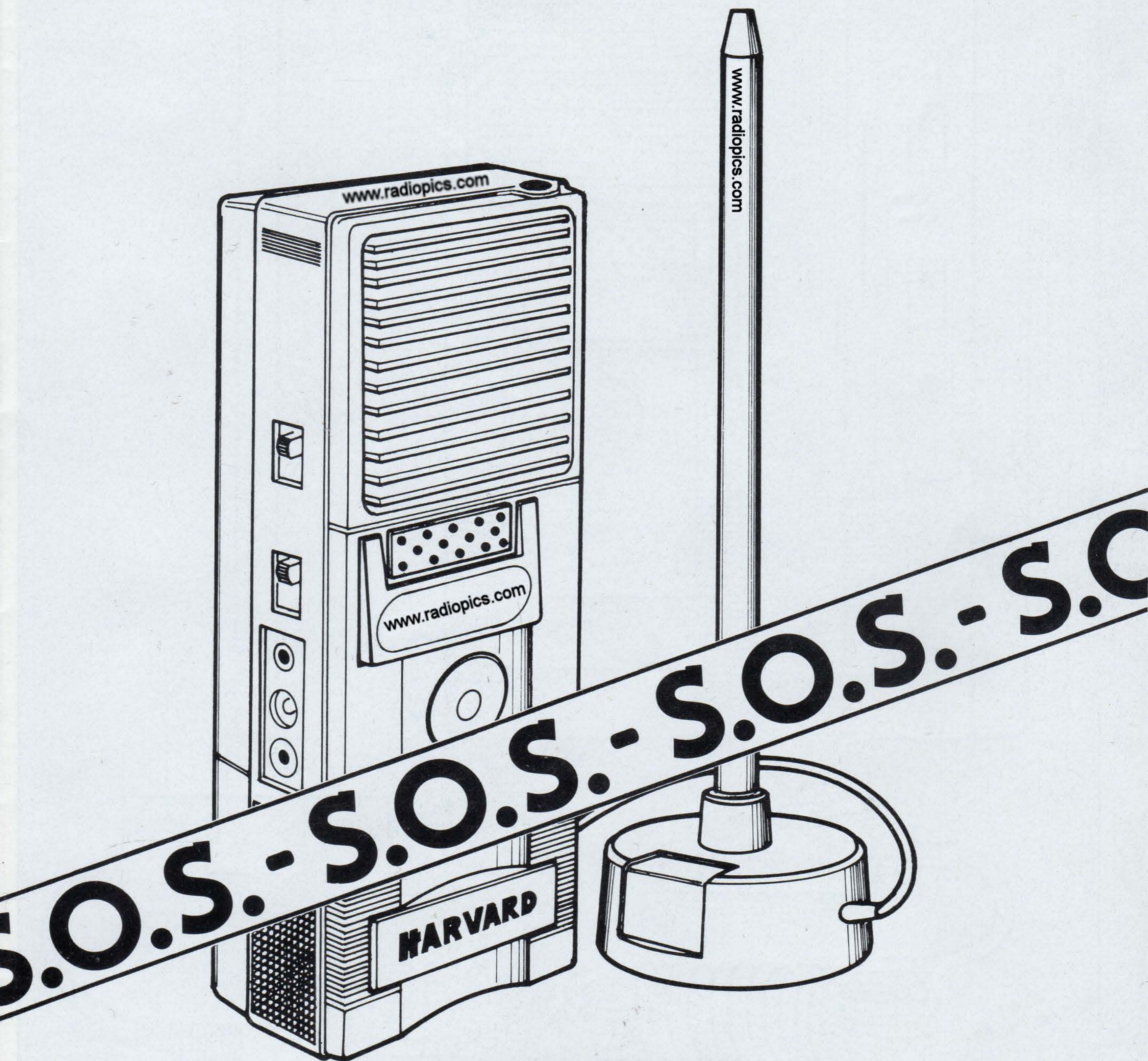

**H-469**  
**OPERATING INSTRUCTIONS**

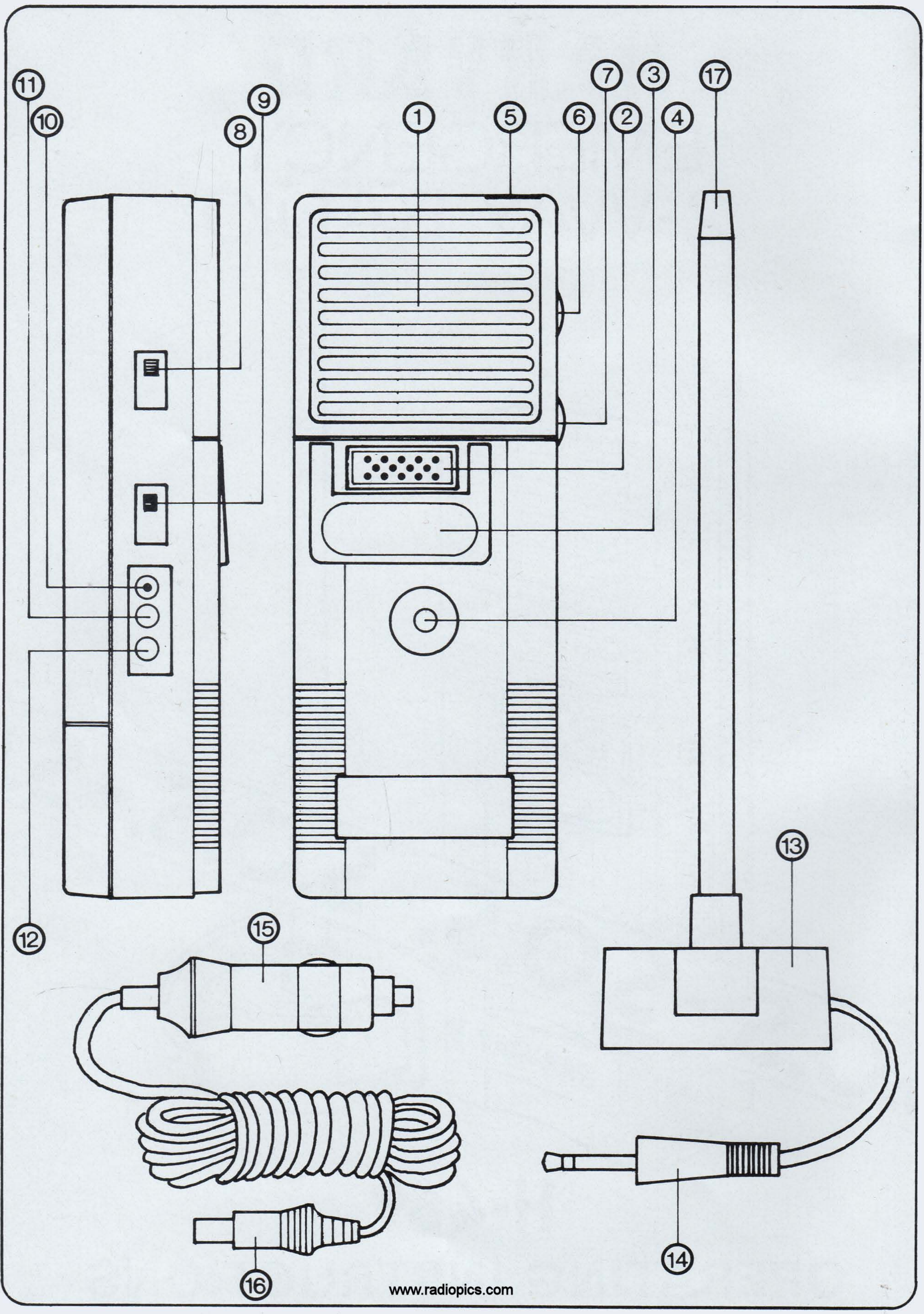

1. Speaker
2. Condenser microphone
3. Push-to-talk bar
4. Low battery indicator
5. Antenna socket
6. Squelch
7. ON-OFF and volume
8. Channel selector
9. Power attenuator
10. Charge socket for NiCad batteries
11. External power socket
12. External antenna socket
13. Magnetic base for antenna
14. Antenna plug
15. 12 Volt DC cigar lighter adaptor
16. 12 Volt DC power plug
17. Extendable antenna

**NOTE:** The magnetic mount antenna supplied with your S.O.S. Emergency 2-Way Radio, is designed for use while your car is not moving or moving very slowly. If you want to use the unit while your vehicle is in motion, insert the extendable antenna in the transceiver itself. You can also purchase from Harvard International a rubber duck antenna fitting the magnetic base. This will allow you to use your unit while in motion but with reduced range. This rubber duck can also be inserted in the transceiver itself.

## **OPERATING INSTRUCTIONS**

### **Power Supply**

**On batteries:** for best results use either Nickel Cadmium AA rechargeable batteries or high power UM3 size batteries, preferably alkaline, such as Duracell, Eveready or equivalent.

If you don't use Nickel Cadmium batteries, check battery compartment periodically for leakage.

### **External power supply**

- insert the 12 Volt DC car adaptor (15) into the cigar lighter socket, plug the other end (16) into external power socket. (11)
- Through an AC-DC adaptor (12V 600MA), you can plug your 2-Way radio in any mains outlet and use it as a base station.

## Antenna

Screw the antenna into the magnetic base (13). Fully extend it and place it on the vehicle's roof or on the hood. This antenna is designed for use either with the magnet base, or, directly inserted into the emergency 2-Way radio if unit is to be used away from vehicle (5).

## Operation

After inserting extendable antenna and connected the power supply, turn power on by rotating volume (7) upwards and adjust volume for a suitable listening level.

Select the desired channel with channel selector (8).

Adjust squelch control (6) to cut out annoying background noise when no signal is being received. To do this rotate the control fully downwards then rotate slowly upwards to the point where the background noise just stops. Now, when a signal is present, you will hear it but you will not be disturbed by noise in between signals.

If you want to receive also very weak signals, leave the squelch control in "open" position, i.e. fully downwards.

Select the desired channel.

### **USE CHANNEL 9 ONLY FOR EMERGENCY.**

Press the push-to-talk bar. Hold the unit about 2"-4" (5-10 CM) from your mouth and speak in a normal voice.

To receive, release the push-to-talk bar.

## Important Notes:

- Never transmit without first connecting the antenna.
- This unit has been designed and manufactured in accordance with Home Office Regulation MPT 1320.
- Channel 9 is to be used for 'emergency' only.

## 10-CODES

Citizens band radio operators have largely adopted the 10 codes for standard questions and answers. Its use permits faster communication and better intelligibility in noisy areas. The following table lists some of the more common codes and their meanings.

Code	Meaning	Code	Meaning
10-1	Receiving poorly	10-13	Advise road/weather conditions.
10-2	Receiving well	10-20	What is your location?
10-3	Stop Transmitting	10-33	Emergency traffic
10-4	OK	10-36	Correct time
10-7	Out of Service	10-41	Switch to Channel.
10-8	In Service	10-62	Cannot copy you.
10-9	Repeat		

## NOISE

In Mobile operation, your vehicle or boat can be the cause of much noise interference. Since the receiver section of your transceiver is very sensitive, it will pick up even the smallest noise signals and amplify them. Any noise that you hear in the transceiver is almost totally from external sources. The receiver itself is exceptionally quiet. If the noise is continuous and fairly loud, it cannot be totally eliminated by the Automatic Noise Limiter circuit. You must solve the problem as its source.

To find out if the noise is from your ignition system, try this simple test. Turn off your ignition switch and set it to ACC (accessories). This turns off the ignition, but supplies power to the Transceiver. Most of the noise will probably disappear, indicating that the source of noise is your vehicle's ignition or other electrical systems.

Ignition-type noise can be identified by the fact that it varies with the speed of the engine. It contains of a series of popping sounds. There are a number of things that can be done to reduce this type of noise.

1. Use only the "radio suppression type" high-voltage ignition wire. Most new cars come already equipped with this type of wire.
2. Inspect the high voltage ignition wire and all connections made with this wire. Old ignition wire may develop leakage, resulting in hash.
3. If noise persists, replace the spark plugs with the spark plugs that have suppressor resistors built-in. Be sure to use the correct type for your vehicle.

Other sources of noise are: generator/alternator, regulator, gauges and static discharge. Most of these types of noise can be efficiently reduced or eliminated by using bypass capacitors at the various output voltage points.

## SERVICE AND MAINTENANCE

Your Transceiver has been built in accordance with HARVARD'S exacting quality control standards. However, it should be treated with reasonable care accorded any electrical equipment. Avoid exposing it to severe shock, dirt or moisture.

If you run into problems with the unit, we recommend you check the following:

1. If trouble is experienced with receiving:  
Check the VOLUME ON/OFF switch setting.  
Be sure squelch is adjusted properly.  
Check if the unit is switched to an active channel.
2. If trouble is experienced with transmitting:  
Check if the transmission line is securely connected to the Antenna Jack.  
Check if the antenna is properly installed.  
Make sure you are fully pressing the PUSH TO TALK Bar.
3. If the Transceiver is completely inoperative:  
Check the 12 VOLT DC CAR ADAPTOR and in-line fuse (Replace only with an identical 2-amp fuse).

### FUSE REPLACEMENT

Twist to open 2 Amp fuse holder.

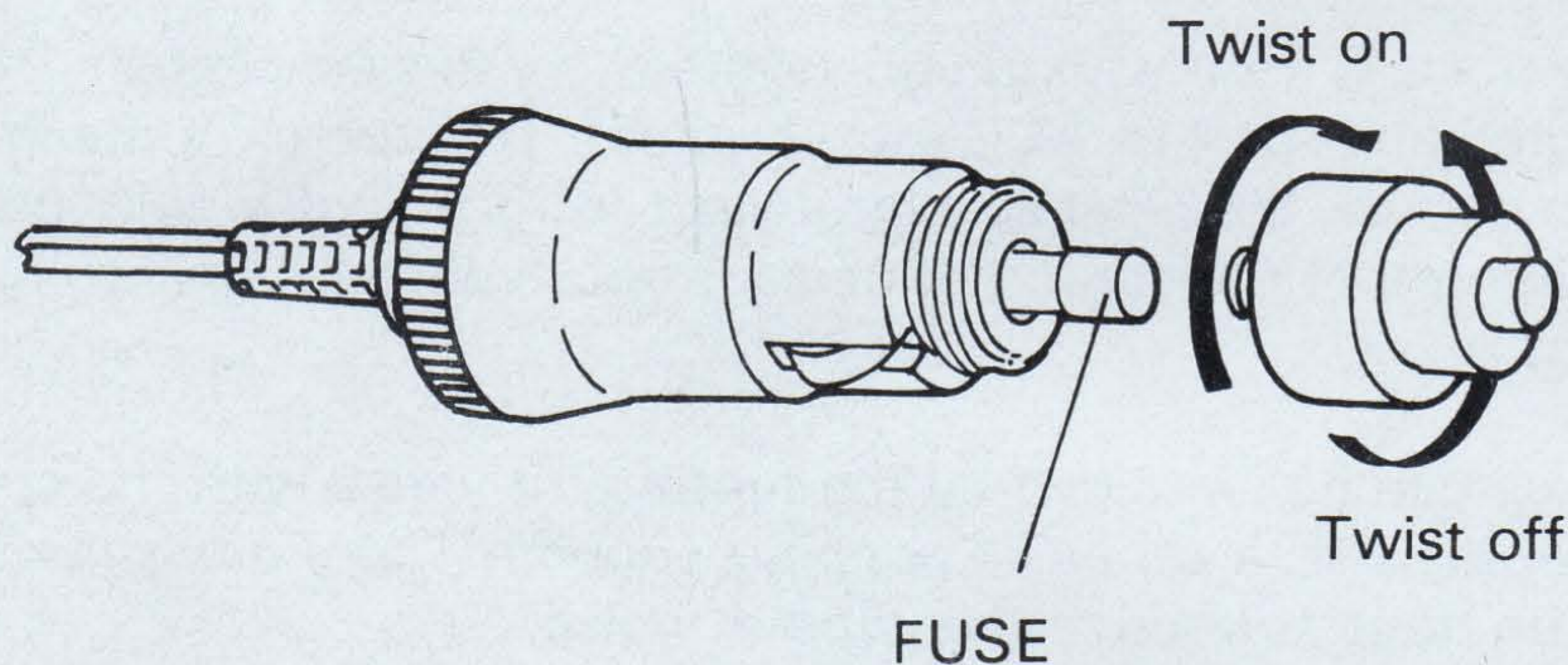

If these checks do not solve the trouble, do NOT attempt repairs or adjustments yourself. The unit should be serviced only by a qualified radio technician. Whenever possible, return the unit to the store from which it was purchased.

## Specifications

3 channel transceiver, channel 9, 14, 30.

18 Transistors, 1 IC, 15 Diodes, 1 LED.

Antenna: length 150 cm, 10 sections, chromed.

Power supply: 12 Volt DC ext. jack (cigar lighter or adaptor).

Batteries: 8 × 1.5 V UM-3 size batteries or 10 × 1.2 Volt NiCad. rechargeable AA size.

### Transmitter

3 stages

Frequency modulation: F3

Modulation capability: 2.5 KHz/Dev.

Built-in condenser microphone

RF output power: HI-4 Watt

LO-0.400 Watt

Battery drain: 700 mA at 4 W.

### Receiver

Superhetrodyne with RF amplifier.

Sensitivity: 0.7 uV for 10 dB S + N/N

IF: 455 KHz

Ceramic filter

Squelch control

Audio output: 500 mW

Battery drain in standby: 60mA

Because we continually strive to improve our products we may change specifications without prior notice.

# CIRCUIT DIAGRAM

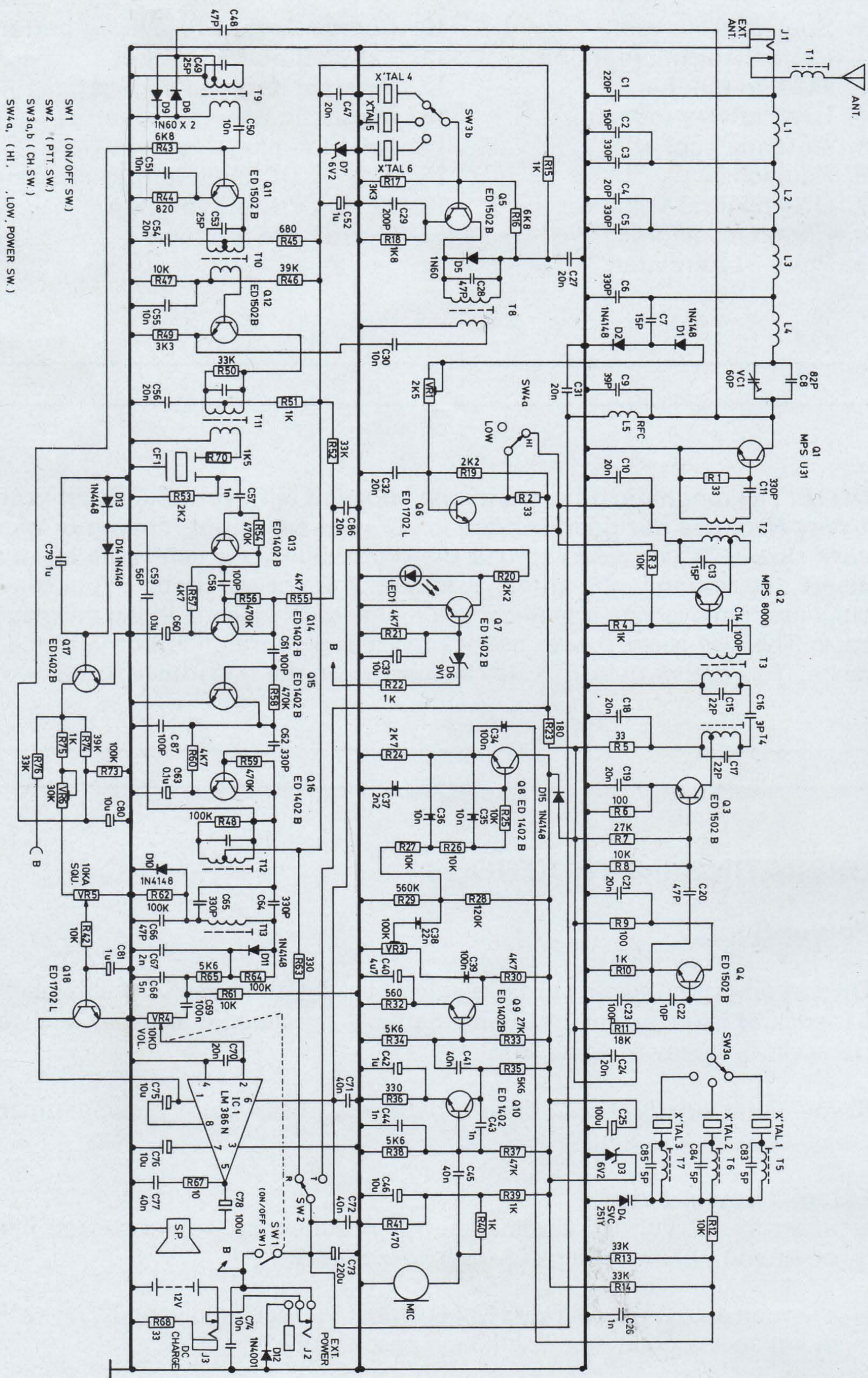

SW1 (ON/OFF SW.)  
SW2 (PT. SW.)  
SW3a,b (CH. SW.)  
SW4a, (HI., LOW, POWER SW.)